

## 1. ZÖLLNER Electronic Bell and Gong System ZBG 110

acc. to the Colregs 1972 Rule 33 and Annex III, 2(a)  
BSH/49/20 G/94

### Bell - Electronic Sound Emitter System

sound pressure level = 110 dB/1 m  
drawing SP 14060-4  
amplifier unit ZB with electronic sound generator  
with original "ship bell characteristic"  
all electronic parts in a weather resistant aluminum casing  
protection type IP 56  
dimensions 260 x 160 x 90 mm  
input 500 W  
approx. net weight 5 kg

### Gong - Electronic Sound Emitter System

for vessels more than 100 m  
sound pressure level = 110 dB/1 m  
drawing SP 14061-4  
amplifier unit ZG with electronic sound generator  
with original "ship gong characteristic"  
all electronic parts in a weather resistant aluminum casing  
protection type IP 56  
dimensions 260 x 160 x 90 mm  
input 500 W  
approx. net weight 5 kg



Elektronische Glocke  
Electronic Bell

ZB 110

SP  
14060-4

Glocke-Elektronik-Schallsender ZB 110  
Bell-Electronic-Sound -Emitter ZB 110

Gewicht : 2,0kg  
Weight :

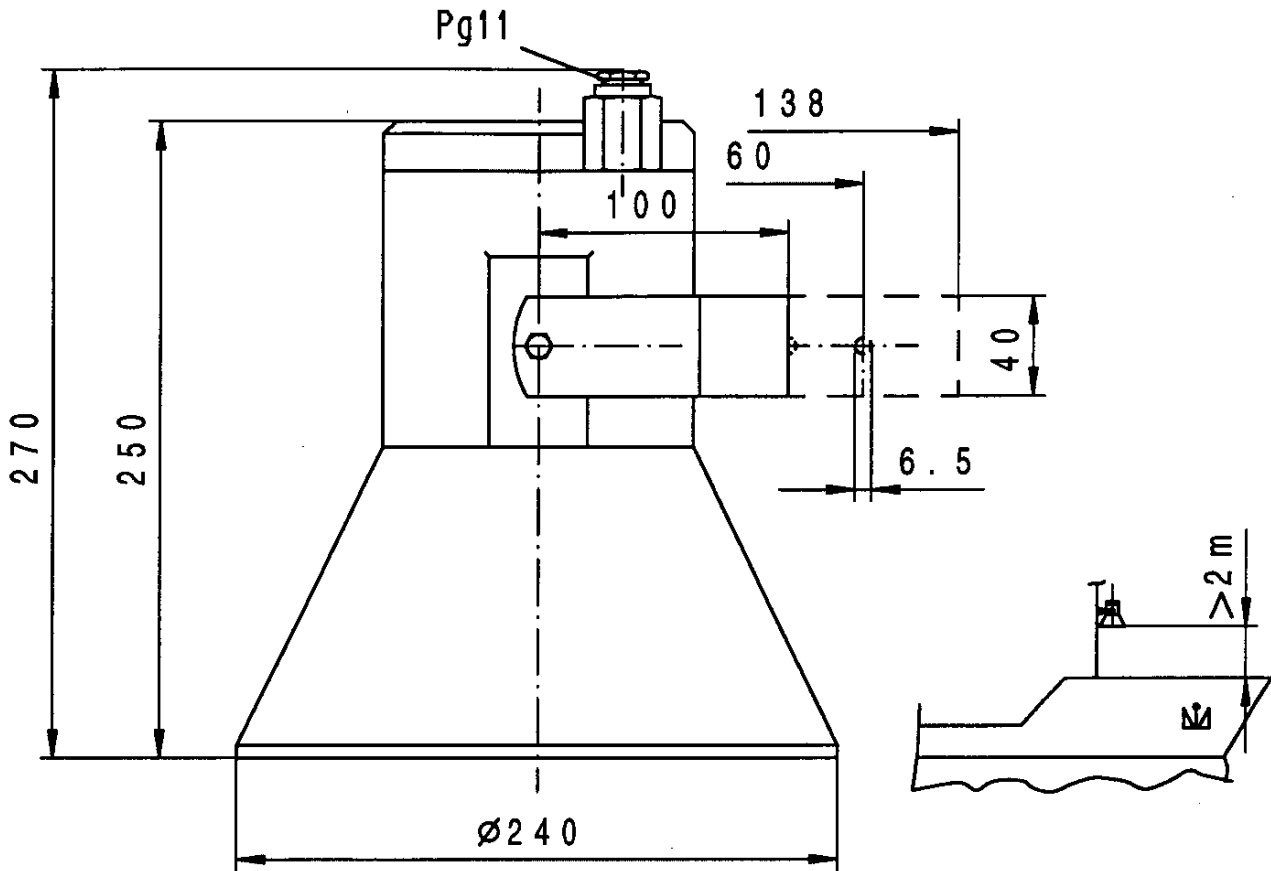

Schalldruckpegel :  
Sound Level : 110 dB(A)/1m

Verstärkereinheit ZB 110  
Amplifier Unit ZB 110

Gewicht : 3,0kg  
Weight :

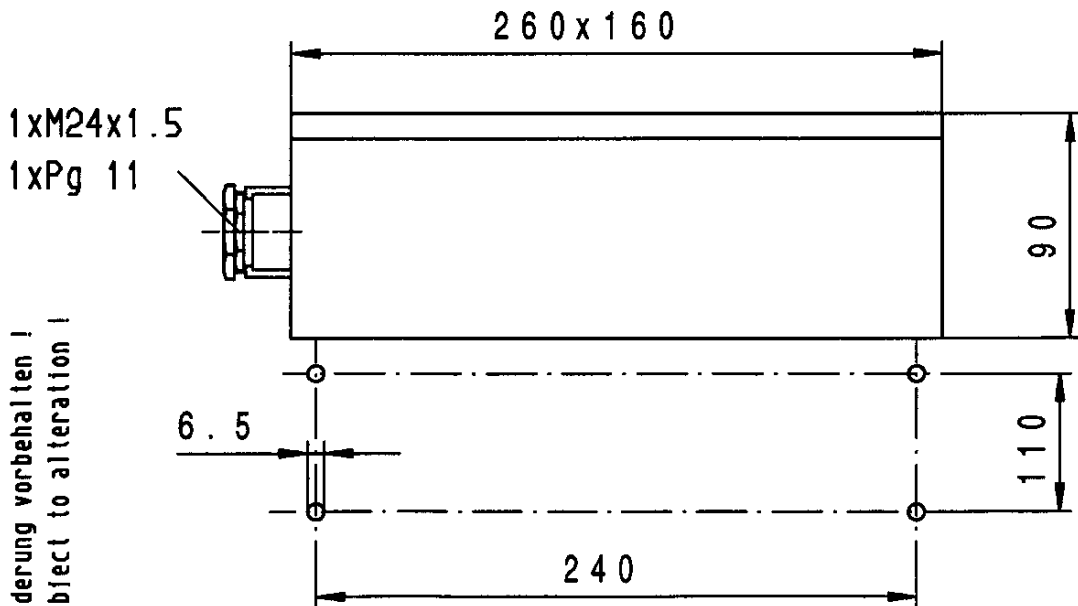

Anderung vorbehalten !  
Subject to alteration !

02.05.96 Sch.  
22.12.94 Sch.

ZÖLLNER • KIEL



Elektronischer Gong  
Electronic Gong

ZG 110

SP  
14061-4

Gong-Elektronik-Schallsender ZG 110  
Gong-Electronic-Sound -Emitter ZG 110

Gewicht : 2,0kg  
Weight :

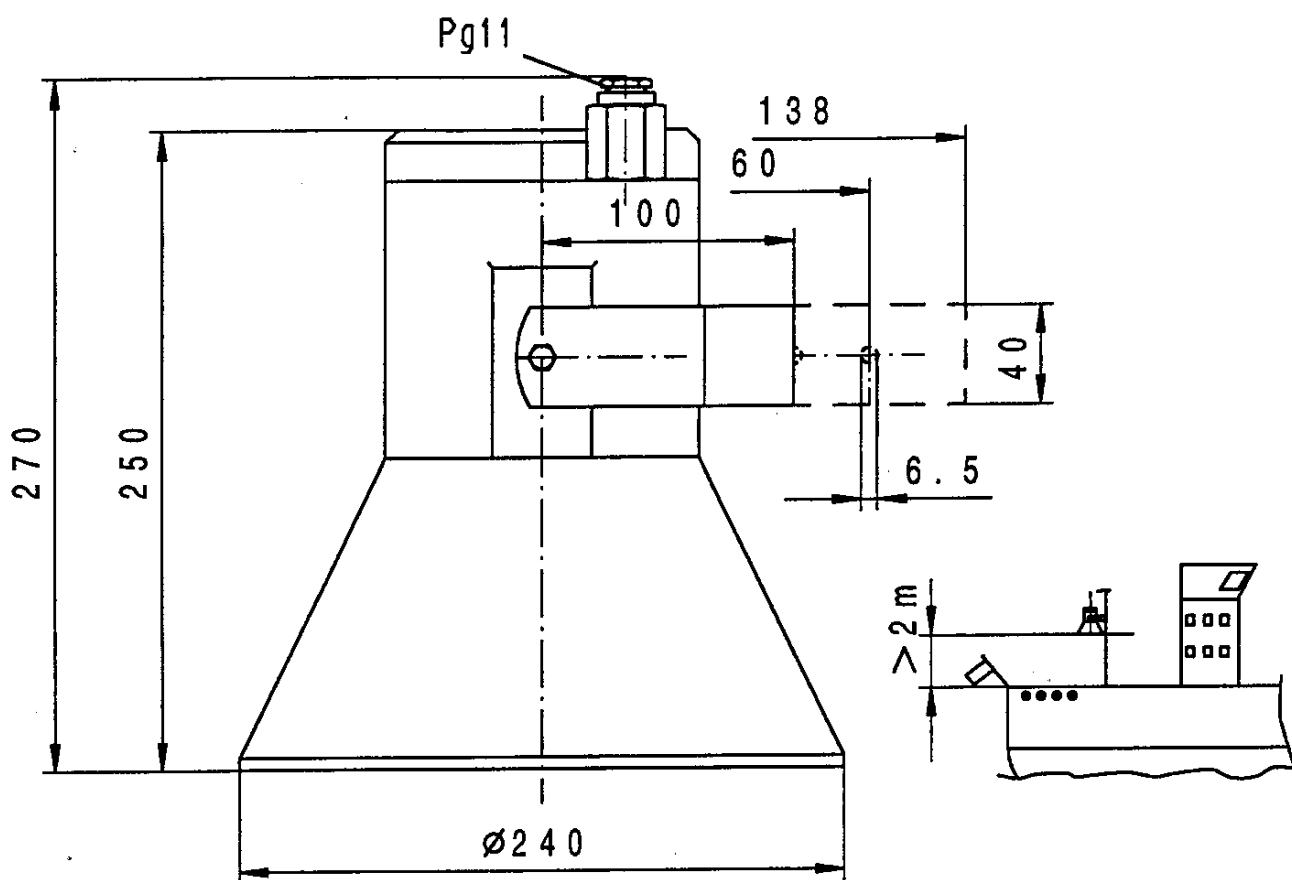

Schalldruckpegel : 110 dB(A)/1m  
Sound Level :

Verstärkereinheit ZG 110  
Amplifier Unit ZG 110

Gewicht : 3,0kg  
Weight :

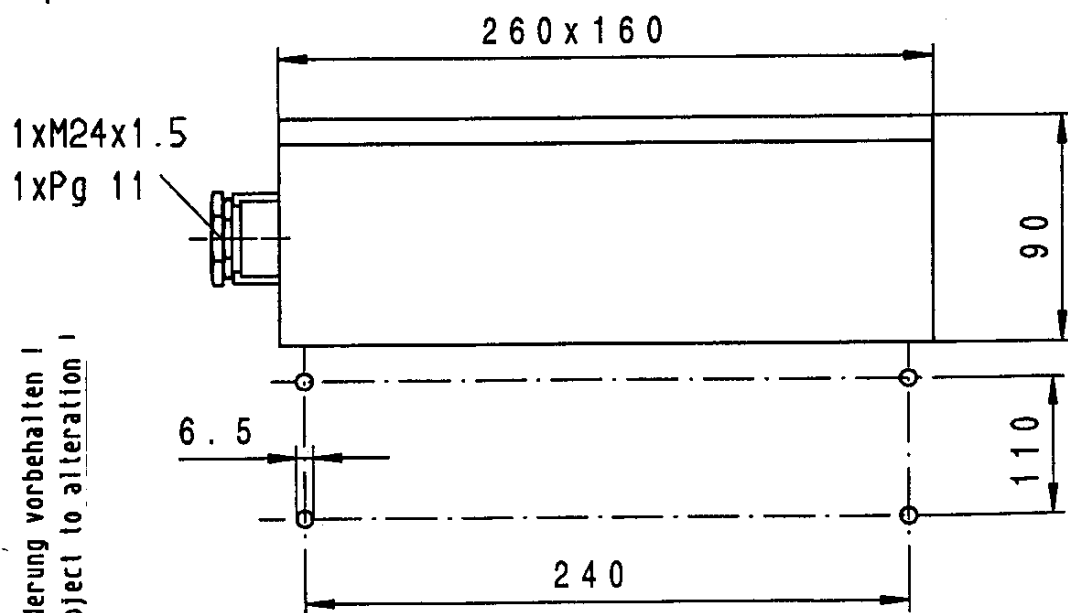

Anderung vorbehalten !  
Subject to alteration !

02.05.96 Sch.  
22.12.94 Sch.

ZÖLLNER • KIEL

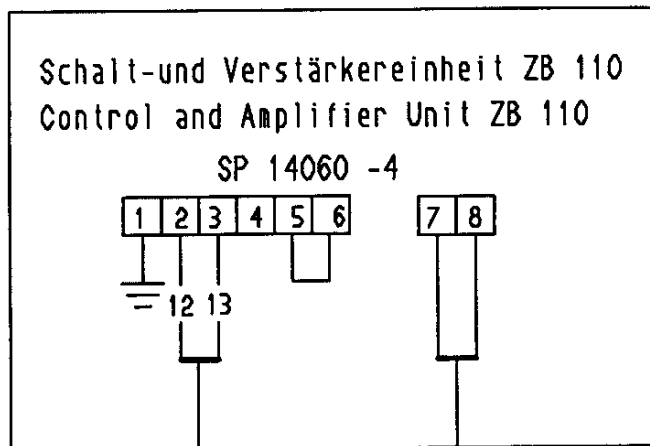

Automat/Automaton  
 10 + SBG

Glocke/Bell  
 ZB 110

Kabellänge/lenght of cable  
 max./appr. 20m

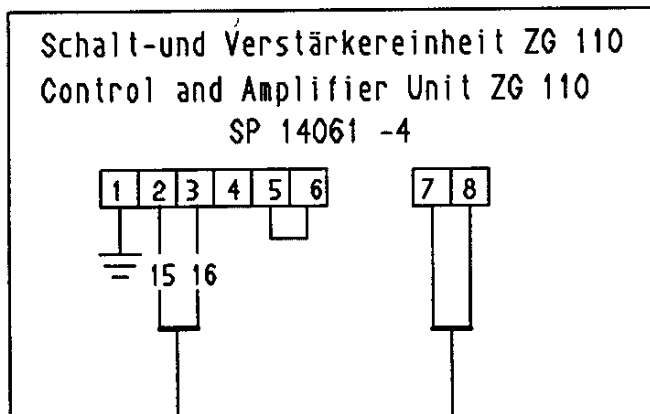

Automat/Automaton  
 10 + SBG

Gong  
 ZG 110

Gong nur für Schiffe  
 Über 100m Länge!  
 Gong only for vessels  
 of more than 100m  
 in lenght!

Kabellänge/lenght of cable  
 max./appr. 20m

Änd. hing vorbehalten!  
 Subject to alteration!