

The Signal Automaton 1+ consists of a switch unit 0144973 and a switch box 0144619.

After installation into the bridge console and electric connection the switch unit is ready for operation at any time. The switch box shall be installed within the navigation bridge.

The Signal Automaton 1+ serves to release automatically the sound signals in accordance with Rule 35 (g) of the Colregs 1972, which reads:

"A vessel at anchor shall at intervals of not more than one minute ring the bell rapidly for about 5 seconds. In a vessel of 100 metres or more in length the bell shall be sounded in the forepart of the vessel and immediately after the ringing of the bell the gong shall be sounded rapidly for about 5 seconds in the after part of the vessel. A vessel at anchor may in addition sound three blasts in succession, namely one short, one prolonged and one short blast, to give warning of her position and of the possibility of collision to an approaching vessel."

Activating the switch unit of the Signal Automaton the program is released automatically until it is deactivated again.

With the hand key for bell and gong single signals may be released.

A hand release required according to Annex III of the Colregs 1972 is possible with a "bell rope" - part 21 of drawing 7332.

The angle of pull as shown on drawing SP 4630 shall be adhered to (a possible security device for transportation must be removed).

Always state the Serial Number of the unit when placing a spare parts order.

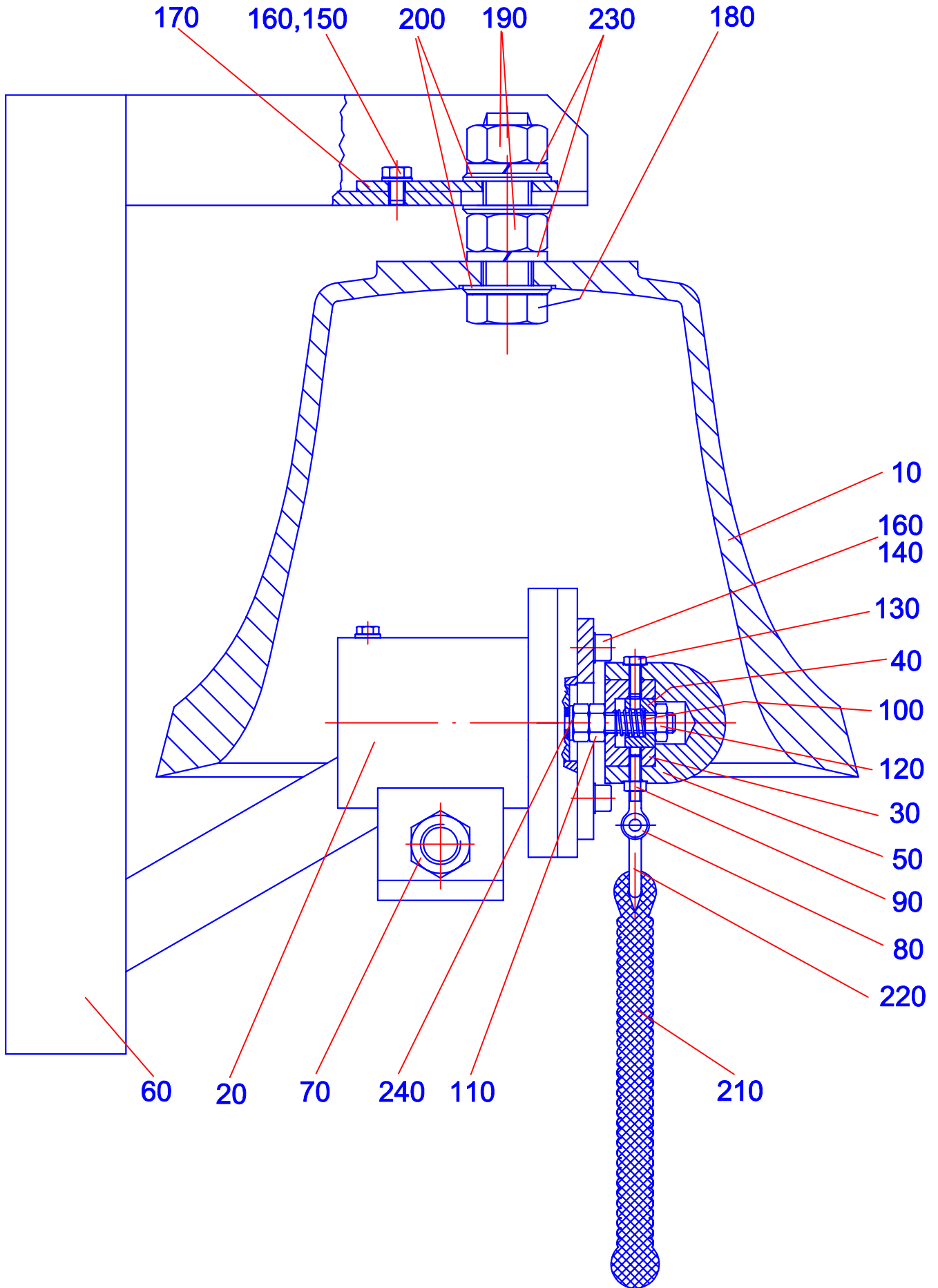

Pos. Item	Stck. Qty	Bestell-Nr. Order-No.	Techn. Daten Techn. Data	Bezeichnung	Designation
10	1	0105859	Ø 350	Glocke	bell
20	1	883001000	200N/15mm	Gleichstrommagnet	DC magnet
30	1	0104649	Ø 45 x 25	Klöppeleinsatz	striker insert
40	1	0104650	Ø 24 x 15	Spannbuchse	fixing bush
50	1	0104648	Ø 60 x 60	Klöppel	striker
60	1	0104641	485x285	Halter	holder
70	1	677072415	M 24x1,5	Kabelverschraubung	cabl gland
80	1	2011060402	BM 6x40	Augenschraube	eye bolt
90	1	21034061	M 6	Sechskantmutter	hexagon nut
100	1	0103651	Ø 12 x 20	Druckfeder	pressure spring
110	2	21034101	M 10	Sechskantmutter	hexagon nut
120	1	21037101	VM 10	Sicherungsmutter	safety nut
130	1	2044060161	M 6x16	Sechskantschraube	hexagon screw
140	4	2035080301	M 8x30	Zylinderschraube	cylinder screw
150	1	2044080161	M 8x16	Sechskantschraube	hexagon screw
160	5	211300081	8x14,8x2	Sicherungsscheibe	safety washer
170	1	0104106	50x5x100	Sicherungsblech	safety plate
180	1	2044240901	M 24x90	Sechskantschraube	hexagon screw
190	2	21034241	M 24	Sechskantmutter	hexagon nut
200	3	211100251	B 25	Scheibe	washer
210	1	883003310	Ø 25x220	Glockenbändsel	bell rope
220	1	883003410	Ø 6 / W13	Schäkel	shackle
230	2	211120241	B 24	Federring	spring washer
240	1	211100101	A 10,5	Scheibe	washer

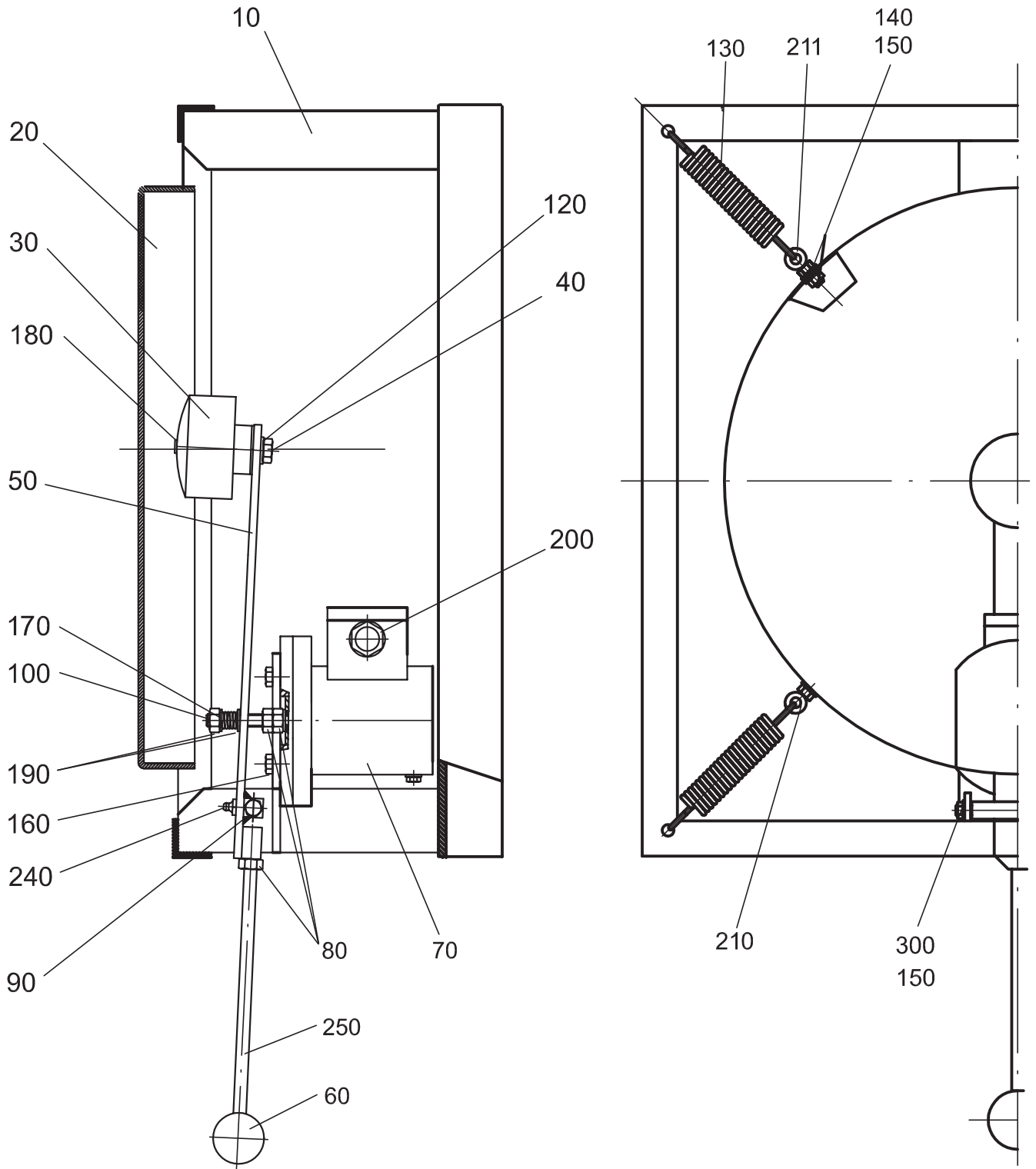

Änderung vorbehalten! Subject to alteration!

Pos. Item	Stck. Qty	Bestell-Nr. Order-No.	Techn. Daten Techn. Data	Bezeichnung	Designation
10	1	0104090	640x640x258	Halter	holder
20	1	883005000	Ø 500	Gong	gong
30	1	0104093	Ø 80 x 60	Klöppel	striker
40	1	2044100201	M 10x20	Sechskantschraube	hexagon screw
50	1	01046471	340x40	Hebel	lever
60	1	57004010	Ø 40	Kugelknopf	ball end of lever
70	1	883001000	200N/15mm	Gleichstrommagnet	DC magnet
80	3	21034101	M 10	Sechskantmutter	hexagon nut
90	1	2043081001	M 8x100	Sechskantschraube	hexagon screw
100	1	21037101	VM 10	Sicherungsmutter	safety nut
120	1	211100101	Ø 10,5	Scheibe	washer
130	4	0104105	Ø 26,7	Zugfeder	traction spring
140	6	21034081	M 8	Sechskantmutter	hexagon nut
150	10	211100081	Ø 8,4	Scheibe	washer
160	4	2035080301	M 8x30	Zylinderschraube	cylinder screw
170	1	0104184	Ø 10/1,3x28	Druckfeder	spring
180	1	0102963	Ø16x18/M5x15,5	Linsenschraube	oval head screw
190	2	211100081	A 8,4	Scheibe	washer
200	1	677072415	M 24x1,5	Kabelverschraubung	cable gland
210	2	01905942	M8x77	Spannöse	stretching eye
211	2	2011080402	BM 8x40	Augenschraube	eye bolt
240	1	556154101	M 10x1	Schmiernippel	grease nipple
250	1	0104646	Ø M10x250	Gewindestange	tie rod
300	1	21037081	VM 8	Sicherungsmutter	safety nut

Änderung vorbehalten! Subject to alteration!

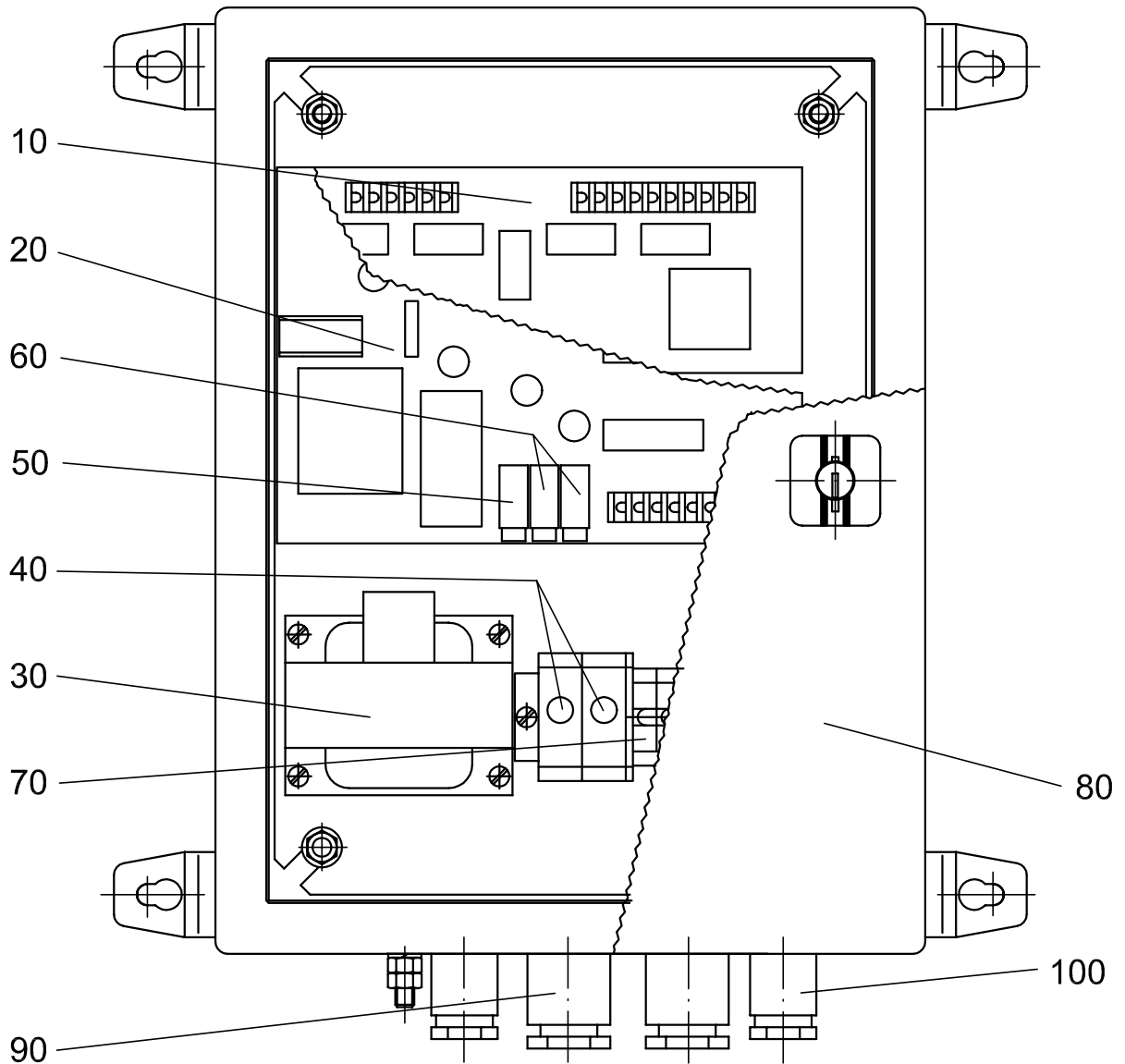

Pos. Item	Stck. Qty	Bestell-Nr. Order-No.	Techn. Daten Techn. Data	Bezeichnung	Designation
10	1	0116100	224x90x1,5	Relaisplatine	relay pc board
20	1	0116694	224x159x1,5	Steuerplatine	control pc board
30	1	6800102042	100VA/230V	Transformator	transformer
40	2	683708906	6,3A Ø5x20	Sicherung	fuse
50	1	683320105	0,5A Ø5x20	Sicherung	fuse
60	2	683320140	4,0A Ø5x20	Sicherung	fuse
70	1	7484.70		Klemmleiste kompl.	terminal compl.
80	1	8870029991	300x400x200	Gehäuse	housing
90	2	677073002	M30x2	Kabelverschraubung	cable gland
90	2	677023020	M30x2	Gegenmutter	counter nut
100	2	677072415	M24x1,5	Kabelverschraubung	cable gland
100	2	677022415	M24x1,5	Gegenmutter	counter nut